

ZYGLO[®] FLUORESCENT PENETRANT INSPECTION SYSTEM

Method and Equipment Selection Guide

**RELIABLE IDENTIFICATION OF
SURFACE DISCONTINUITIES**

LOW COST, MODULAR SYSTEM

LONG SERVICE LIFE

MINIMAL MAINTENANCE

**FLEXIBLE — CONFORMS TO
WORK FLOW AND AVAILABLE
FLOOR SPACE**

**COMPATIBLE WITH ALL
F.P.I. MATERIALS**

MAGNAFLUX[®]

ZYGLO® FLUORESCENT PENETRANT INSPECTION SYSTEM

The ZYGLO Fluorescent Penetrant Inspection System is a simple, reliable and economical non-destructive test method for disclosure of surface discontinuities in all metal and many non-metallic parts. Installation utilizes modular components which accommodate work flow and space requirements. Particular attention is given to the efficient, low cost disposition of waste water.

MAJOR BENEFITS

RELIABLE IDENTIFICATION OF SURFACE DISCONTINUITIES

LOW COST, MODULAR SYSTEM

LONG SERVICE LIFE

MINIMAL MAINTENANCE

FLEXIBLE — CONFORMS TO WORK FLOW AND AVAILABLE FLOOR SPACE

COMPATIBLE WITH ALL F.P.I. MATERIALS

ZyglO inspection equipment is designed to facilitate what is, essentially, a five step process:

1. Application of penetrant to part being tested with time allowed for penetration into any discontinuities.
2. Removal of excess penetrant from surface of part.
3. Drying of part.
4. Application of developer to make entrapped penetrant easier to see.
5. Inspection of the part under a black light for surface discontinuities.

In each of the above steps there are options relating to the material being tested, method used, part size, part handling and waste disposition. Before processing, parts must be cleaned to remove all foreign matter.

SYSTEM SELECTION

Five basic decisions are required in selecting an appropriate ZyglO Fluorescent System:

1. The Part Envelope required.
2. Whether a Water Washable or Post Emulsified method would work best on your parts.
3. Whether spraying or immersion is best for your parts.
4. Whether Wet or Dry developer is to be used.
5. Facility requirements (Electrical Specifications, Pneumatic Lines, etc.).

PART ENVELOPE

Four standard size modular systems are available to accommodate a wide range of part sizes. Each piece of equipment within each system is compatibly sized.

Select the system that best accommodates the maximum size parts that you will be processing.

Dimensions are in inches and are nominal

STANDARD SIZE MODULAR SYSTEM	SYSTEM INSIDE WORKING DIMENSIONS				PASS LINE
	LENGTH	WIDTH	HEIGHT*	HYDROPHILIC SYSTEM HEIGHT*	HEIGHT FROM FLOOR (INCHES)
2436	33	21	26	25	36
4040	36	34-1/2	35	34	43
3448	43-1/4	29	28	27-1/2	36
3472	67-1/4	29	28	27-1/2	36
5472	67-1/4	49	28	27-1/2	36

* These dimensions will be slightly reduced if a Power Immersion Grille is used. Refer to specific "Inside Dimensions" on appropriate equipment pages.

The greatest economy is achieved when these pre-sized modular systems are specified. Other equipment is available for larger or smaller sized parts.

WATER WASH VS. POST EMULSIFIED (HYDROPHILIC AND LIPOPHILIC) METHODS

WATER WASH METHOD

The Zyglon penetrant used in the Water Wash method does not need an emulsifier to facilitate the surface cleaning process. Water Wash is the simplest and quickest “floor-to-floor” method available. Care must be taken to assure that overwashing does not occur.

POST EMULSIFIED METHOD (HYDROPHILIC AND LIPOPHILIC)

The Hydrophilic method is the most sensitive and reliable fluorescent penetrant

inspection technique. Because of its waste disposal economies, it is gradually replacing the Lipophilic method. Easy separation of penetrant (for disposal) from pre-rinse (for re-use) is a major benefit of the Hydrophilic method. This method involves more processing steps than the Water Washable method, but provides better control and less susceptibility to overwashing.

The Lipophilic method is similar to the Hydrophilic method, but with important differences:

1. Pre-rinsing of excess penetrant is not recommended.
2. In the Hydrophilic method, parts remain in the Hydrophilic Remover

through the dwell time. In the Lipophilic method, parts are immersed in the Lipophilic Remover and are immediately withdrawn. Excess penetrant then drains off during the dwell time.

WET VS. DRY DEVELOPER

The Wet Developer is applied by dipping the parts into the developer. Parts then move into a dryer where the water is evaporated.

With Dry Developer, the parts are first dried and then pass into a chamber where Dry Developer is applied, either by dipping, blowing the developer onto the parts, or passing the parts through a developer “cloud”.

PARTS HANDLING

Other considerations that affect the proper selection of equipment relate to how parts are to be handled. Roller Grilles facilitate the movement of parts between stations.

The largest Zyglon System includes optional split-roof components to accommodate overhead monorail conveyor systems or hoists.

Optional Power Immersion Grilles facilitate lowering and raising large parts, or large baskets of parts, into and out of the processing tanks.

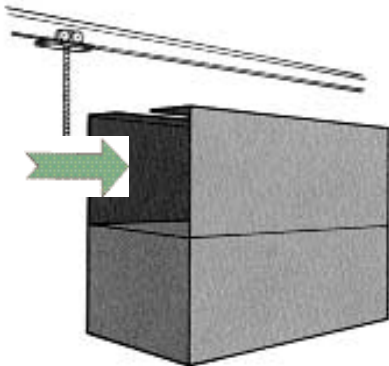

SYSTEM CONFIGURATION

Zyglon Equipment can be positioned to accommodate floor space limitations and work flow requirements. Inspection systems can be set up in a straight line, with left and/or right 90° turns, or in a “U” turn to send parts back in the direction from which they came.

STRAIGHT LINE

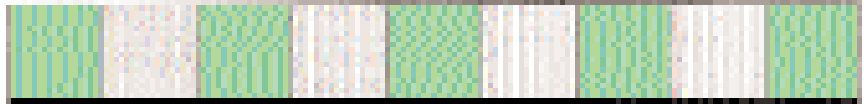

90° BEND/“U” SHAPE

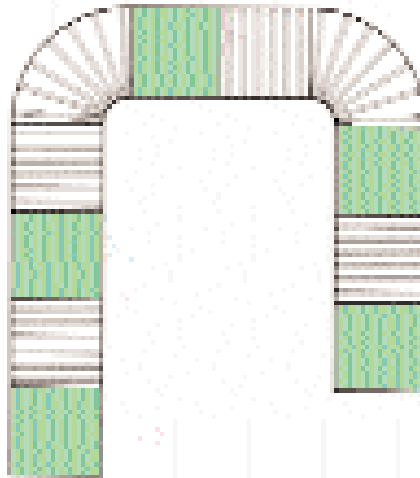

PASS LINE HEIGHT

MODULAR SYSTEM	HEIGHT FROM FLOOR (INCHES)
2436	36
4040	43
3448	36
3472	36
5472	36

ELECTRICAL SPECIFICATIONS

The electrical specifications referenced in this catalog reflect those commonly used in the U.S.A. MAGNAFLUX equipment can be provided that is compatible with any conventional electrical source, worldwide.

ZYGLO® FLUORESCENT PENETRANT INSPECTION SYSTEM

PENETRANT STATION EMULSIFIER STATION (LIPOPHILIC METHOD) WET DEVELOPER STATION IMMERSION TANK



Penetrant Spray Station (not shown) also available.
Contact Magnaflux for information on features and options.

Immersion is the process normally used to apply Penetrant, Emulsifier and Wet Developer to parts surfaces. Depending on part size, a tank from one of the four modular size systems is used for the immersion process.

The use of a Power Immersion Grille (see page 14) to lower and raise large parts or baskets of parts in and out of the tank will slightly affect part clearance. (See chart below.)

FEATURES

- Heavy gauge stainless steel tank
- Structural steel framework
- Bottom supported tank
- Protective hinged tank cover

BENEFITS

- Rapid and complete coverage of parts with complex shapes
- Easier coverage of parts processed in bulk
- Easy handling of large or heavy parts using optional power immersion grille
- Fast, easy installation (floor mount or bolt-together)

SPECIFICATIONS

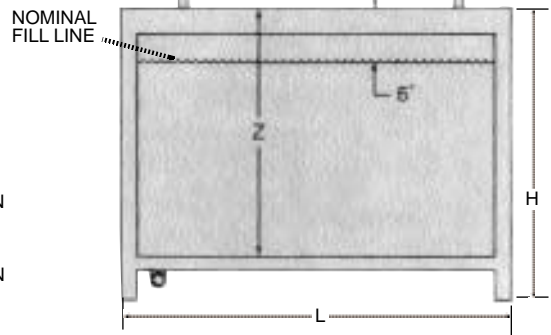
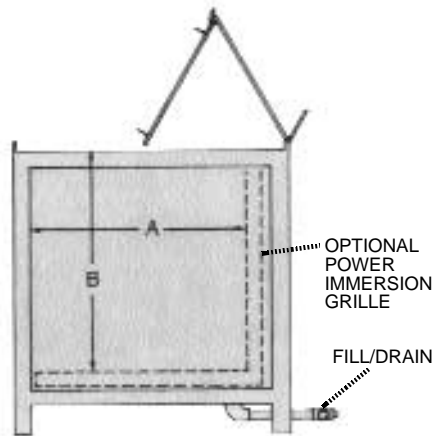
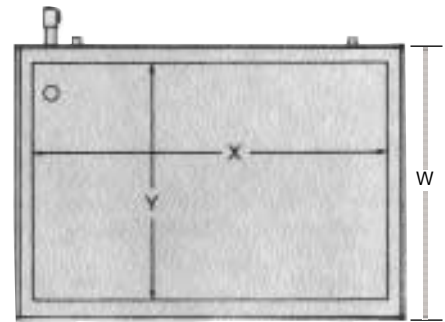

Dimensions are in inches and are nominal

ACCESSORIES

- Half roller grille
- Power immersion grille
- Timers

MECHANICAL REQUIREMENTS

PLUMBING

- Drain and fill connection, rear of tank

STANDARD SIZE MODULAR SYSTEM	OUTSIDE DIMENSIONS			INSIDE DIMENSIONS			INSIDE DIMENSIONS WITH POWER IMMERSION GRILLE			GALLONS PER INCH (HEIGHT)	NOMINAL FILL (GALLONS)
	L	W	H	X	Y	Z	X	A	B		
2436	36	24	36	33	21	26	Available Upon Request			3.0	60
4040	40	40	42-1/2	36	36	36	36	32-1/2	31-1/2	5.6	170
3448	48	34	36	43-1/4	29-1/4	30-3/4	43-1/4	25-3/4	25-1/4	5.5	140
3472	72	34	36	67-1/4	29-1/4	30-3/4	67-1/4	25-3/4	25-1/4	8.5	220
5472	72	54	36	67-1/4	29-1/4	30-3/4	67-1/4	45-3/4	25-1/4	14.3	370

Customized sizes are available upon request

REST STATION
DRAIN STATION
ROLLER GRILLES



Roller grilles support parts during “rest” or “drain” cycles and facilitate the movement of heavy or basketed parts. The stations provide a support area equal to the basic tank size.

Roller grille units can be bolted to adjacent components, or optional support legs may be used. 90° grille units accommodate the turning or reversal of the work flow.

Half-tank roller grilles fit on the modular tanks and provide for direct drainage of material within the tanks. These may be used instead of drain stations in some applications to save space and cost. (Note: Not available for 2436 or 4040 Models)

Drain stations have stainless steel trays to facilitate recovery of Penetrant, Emulsifier, Rinse Water and Wet Developer.

FEATURES

Corrosion resistant rollers - nominal 2" OD on 4" Centers

Synthetic bearings

Interchangeable rollers are easily installed or removed

Note: Model 2436 includes a corrosion resistant rack instead of rollers

Stainless steel drain pan

SPECIFICATIONS ROLLER GRILLE REST STATION

STRAIGHT

ROLLER GRILLE REST STATION

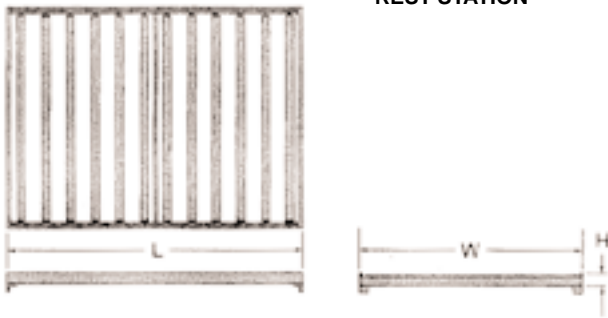

90° TURN

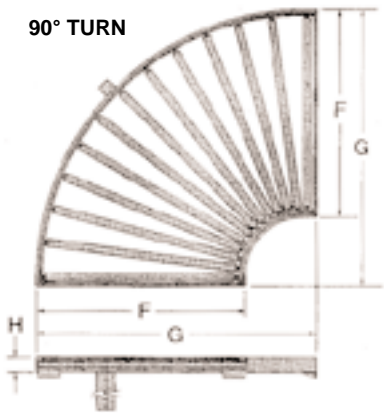

Dimensions are in inches and are nominal

STANDARD SIZE MODULAR SYSTEM	STRAIGHT SECTION			90° SECTION		
	L	W	H	F	G	H
2436*	36	24	36	36	36	36
4040	40	40	2-1/2	40	50	2-1/2
3448	48	34	3	34	44	3
3472	72	34	3	34	44	3
5472	72	54	3	54	72	3

*Not as shown. Slightly different configuration.
 No rollers for 2436 Rest Station

SPECIFICATIONS ROLLER GRILLE DRAIN STATION

STRAIGHT

ROLLER GRILLE DRAIN STATION

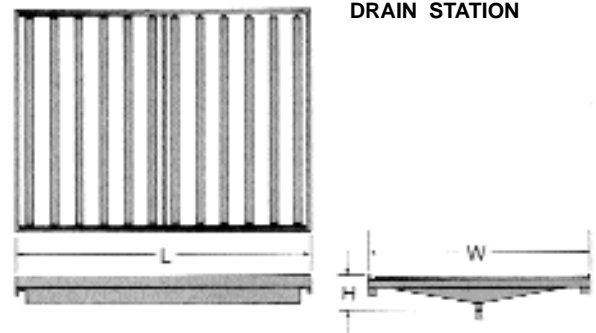

90° TURN

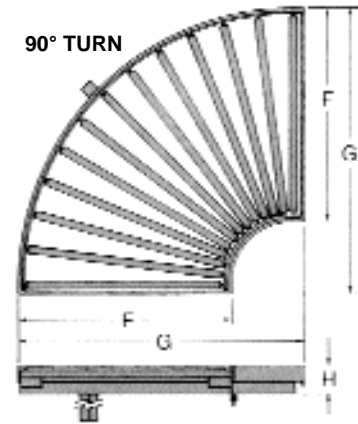

Dimensions are in inches and are nominal

STANDARD SIZE MODULAR SYSTEM	STRAIGHT SECTION			90° SECTION		
	L	W	H	F	G	H
2436*	36	24	36	36	36	36
4040	40	40	8	40	50	7
3448	48	34	8	34	44	7
3472	72	34	8	34	44	7
5472	72	54	9	54	72	7-1/4

*Not as shown. Slightly different configuration.
 No rollers for 2436 Drain

ZYGLO® FLUORESCENT PENETRANT INSPECTION SYSTEM

PRE-RINSE STATION

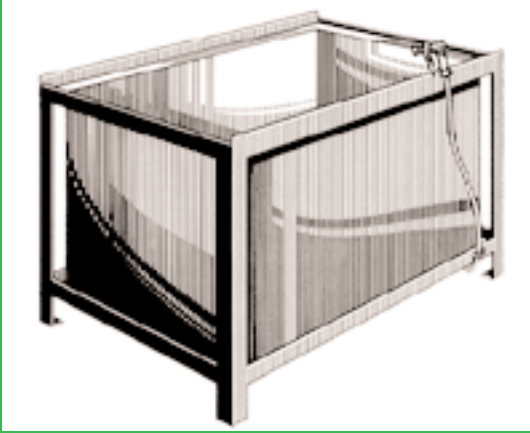

The penetrant must be removed from the part surfaces so that even the smallest flaws are easily detected. A Pre-Rinse station, immediately after Penetrant Application station, allows most of the penetrant to be flushed from the part's surface; thus, relatively little penetrant is carried forward with the part into the Penetrant Remover station and remover life is extended.

FEATURES

- Heavy gauge stainless steel tank
- Structural steel framework
- Hand-held hose with spray nozzle
- Bottom supported tank

BENEFITS

- Removes majority of penetrant before remover is applied
- Facilitates removal of penetrant and re-use of rinse water
- Minimizes effluent of disposal costs

SPECIFICATIONS

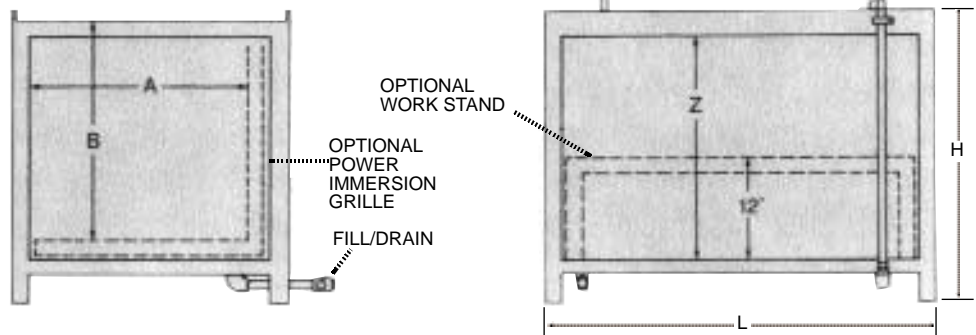
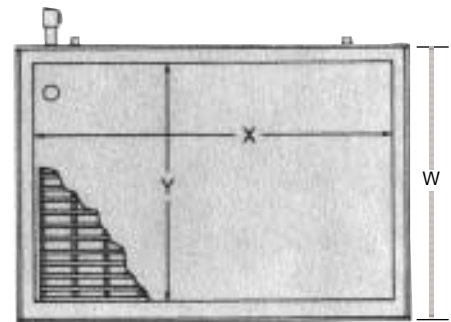

Dimensions are in inches and are nominal

ACCESSORIES

- Hydrowash spray gun
- Half roller grille
- Power immersion grille
- Rear splash shield
- Work stand
- Mixing Valve

MECHANICAL REQUIREMENTS

PLUMBING

- Water inlet connection, rear of tank
- Drain connection, rear of tank

STANDARD SIZE MODULAR SYSTEM	OUTSIDE DIMENSIONS			INSIDE DIMENSIONS			INSIDE DIMENSIONS WITH POWER IMMERSION GRILLE		
	L	W	H	X	Y	Z	X	A	B
2436	36	24	36	33	21	26	N/A	N/A	N/A
4040	40	40	42-1/2	36	36	35	36	32-1/2	31-1/2
3448	48	34	36	43-1/4	29-1/4	29-3/4	43-1/4	25-3/4	25-1/4
3472	72	34	36	67-1/4	29-1/4	29-3/4	67-1/4	25-3/4	25-1/4
5472	72	54	36	67-1/4	29-1/4	29-3/4	67-1/4	45-3/4	25-1/4

Customized sizes are available upon request

REMOVER STATION
 (HYDROPHILIC METHOD ONLY)



A Hydrophilic Penetrant Remover must be applied to the part following Pre-Rinse to assure complete removal of surface penetrant. Application is either by immersion or by spraying. Immersion tanks are equipped with air agitators to achieve the scrubbing action necessary for the remover to be effective. Immersion is recommended for uniform coverage of parts having complex shapes. A Power Immersion Grille is often used to provide additional agitation. The Hydrophilic Penetrant Remover is a concentrate and is added to water (approximately 1 to 5 ratio for immersion, and a 1 to 20 ratio for spray).

Spraying on a remover/water mix may be a more efficient way to cover large, flat-surfaced parts. Uniform distribution of the remover on all surfaces is important.

FEATURES

- Heavy gauge stainless steel tank
- Structural steel framework
- Bottom supported tank
- Air agitation
- Air line regulator, gauge and filter/strainer
- Protective hinged tank cover

BENEFITS

- Provides controlled processing and rinsing results

SPECIFICATIONS

ACCESSORIES

- Power immersion grille
- Timers
- Work stand

MECHANICAL REQUIREMENTS

AIR

- 60 P.S.I. shop air line

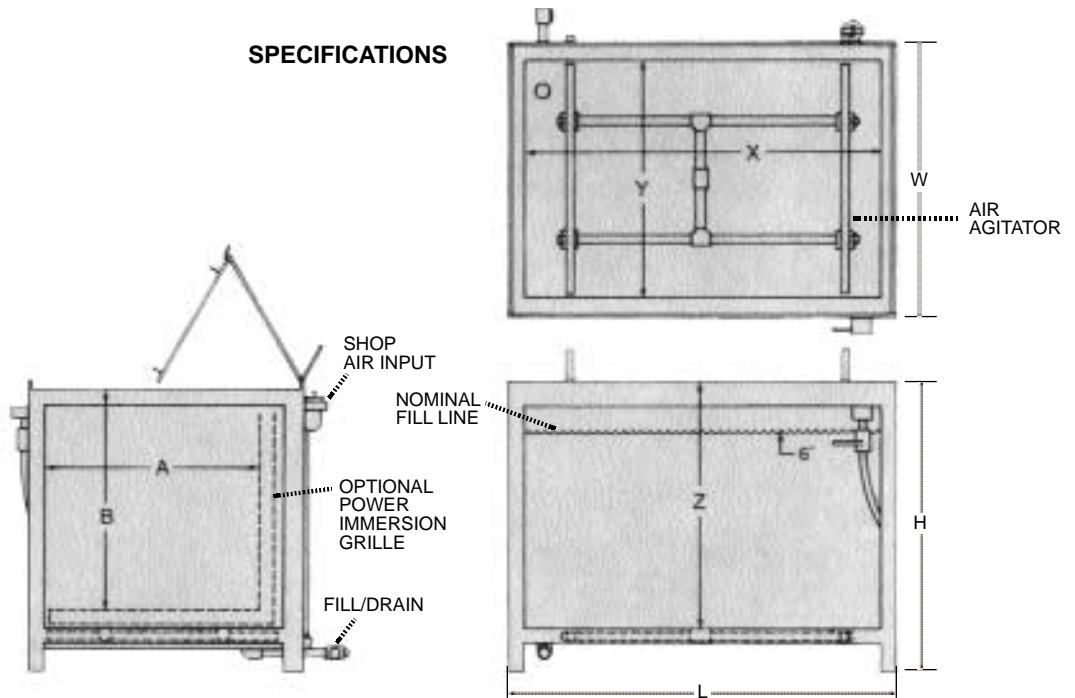

Dimensions are in inches and are nominal

STANDARD SIZE MODULAR SYSTEM	OUTSIDE DIMENSIONS			INSIDE DIMENSIONS			INSIDE DIMENSIONS WITH POWER IMMERSION GRILLE		
	L	W	H	X	Y	Z	X	A	B
2436	36	24	36	33	21	25	Available Upon Request		
4040	40	40	42-1/2	36	36	34	36	32-1/2	31-1/2
3448	48	34	36	43-1/4	29-1/4	29-1/4	43-1/4	25-3/4	25-1/4
3472	72	34	36	67-1/4	29-1/4	29-1/4	67-1/4	25-3/4	25-1/4
5472	72	54	36	67-1/4	49-1/4	29-1/4	67-1/4	45-3/4	25-1/4

Customized sizes are available upon request

ZYGLO® FLUORESCENT PENETRANT INSPECTION SYSTEM

RINSE STATION

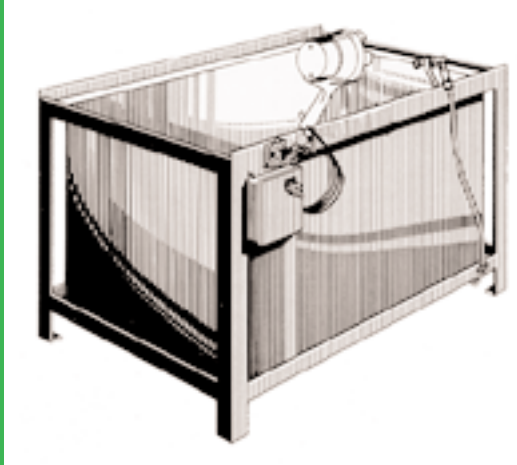

All parts go through “Final Rinse” where all remaining penetrant, whether Water Wash, Hydrophilic or Lipophilic, is removed from the part’s surface.

A black light is provided to insure that proper washing is accomplished.

Final rinsing is done with a hand hose and spray nozzle. A Hydrowash power spray nozzle is a frequently used option for faster cleaning when permitted by specification. Complex shapes may require immersion and then a rinse. An air agitated rinse tank which helps in final clean-up, is available.

FEATURES

- Heavy gauge stainless steel tank
- Structural steel framework
- Bottom supported tank
- Spray hose and nozzle
- Black light

BENEFITS

- Convenient spray containment
- Flexible Operation

SPECIFICATIONS

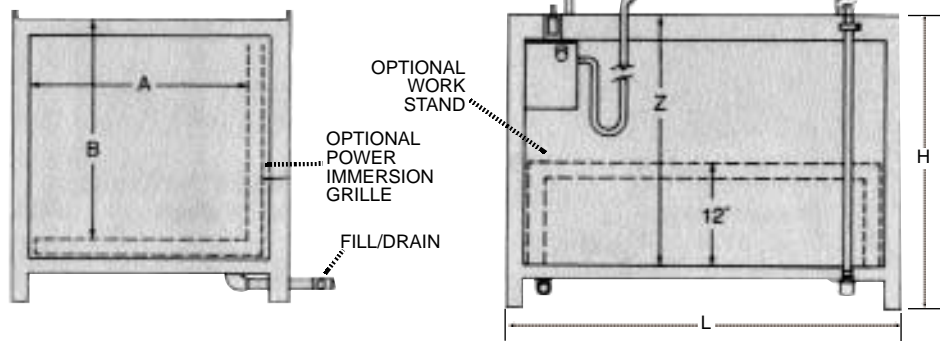
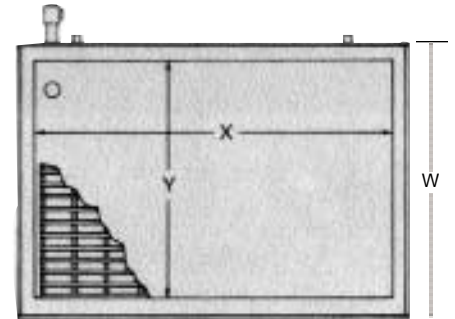

Dimensions are in inches and are nominal

ACCESSORIES

- Hydrowash spray gun
- Half roller grille
- Power immersion grille
- Rinse hood
- Rear splash shield
- Mixing valve
- Work stand
- Remover Injector Kit (Spray System)

MECHANICAL REQUIREMENTS

PLUMBING

- Water inlet connection, rear of tank
- Drain connection, rear of tank

ELECTRICAL

- 115V, 60HZ, 1PH., 4 Amps
(for black light)

STANDARD SIZE MODULAR SYSTEM	OUTSIDE DIMENSIONS			INSIDE DIMENSIONS			INSIDE DIMENSIONS WITH POWER IMMERSION GRILLE		
	L	W	H	X	Y	Z	X	A	B
2436	36	24	36	33	21	25	Available Upon Request		
4040	40	40	42-1/2	36	36	34	36	32-1/2	31-1/2
3448	48	34	36	43-1/4	29-1/4	29-1/4	43-1/4	25-3/4	25-1/4
3472	72	34	36	67-1/4	29-1/4	29-1/4	67-1/4	25-3/4	25-1/4
5472	72	54	36	67-1/4	49-1/4	29-1/4	67-1/4	45-3/4	25-1/4

Customized sizes are available upon request

TABLE TOP RINSE
STATION (OPTIONAL)

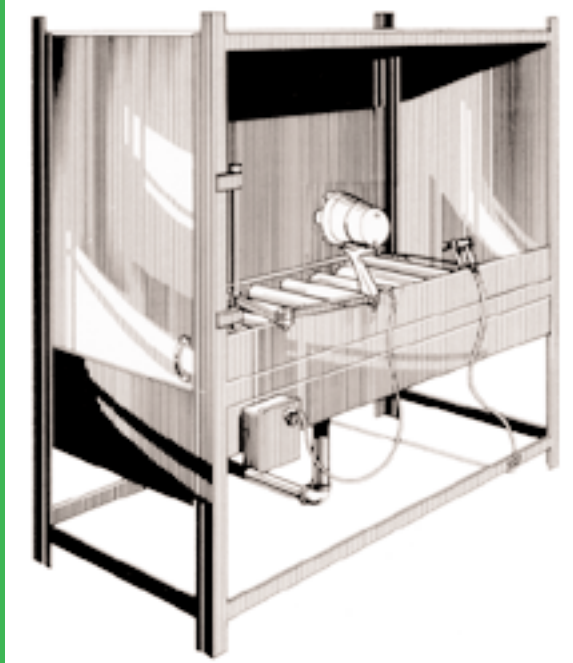

Used in place of the conventional rinse tank, the Table Top Rinse unit permits easy, manual access to hard-to-rinse parts and to parts with entrapment areas that must be turned and emptied after rinsing. Working at waist height reduces fatigue. A roller grille provides an ideal work platform. The Table Top unit includes a hose and spray nozzle and a portable black light for surface inspection. The Hydrowash power spray is a popular option. The Table Top unit includes a hose and spray nozzle and a portable black light for surface inspection. The Hydrowash power spray is a popular option. The Table Top unit is enclosed at three sides and at the top.

A split top unit, with curtained entry and exit, is available in the largest system to accommodate overhead conveyor installations.

FEATURES

- Stainless steel drain pan
- Structural steel frame
- Hand hose
- Hand held black light

BENEFITS

- Easy access to hard-to-rinse parts and parts with entrapment areas
- Operator comfort

ACCESSORIES

- Hydrowash spray gun
- Remover Injector Kit (Spray System)

MECHANICAL REQUIREMENTS

PLUMBING

- Water inlet connection, rear of tank
- Drain connection, rear of tank

ELECTRICAL

- 115V, 60HZ, 1PH., 4 Amps
 (for black light)

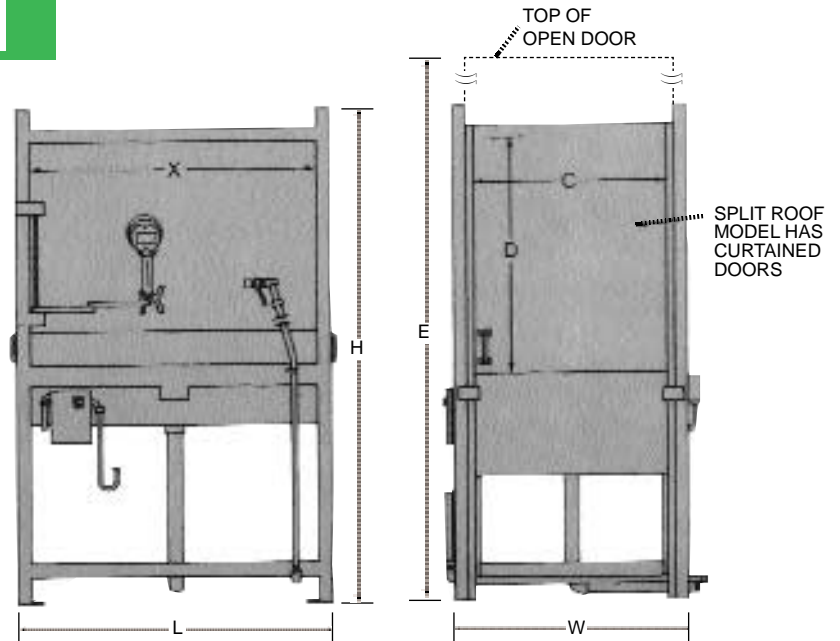

Dimensions are in inches and are nominal

STANDARD SIZE MODULAR SYSTEM	OUTSIDE DIMENSIONS				INSIDE DIMENSIONS		
	L	W	H	E	X	C	D
2436	<i>Available upon request</i>						
4040	40	42	82-1/2	113	36	34-1/2	33-1/2
3448	48	36	75	105-1/2	44	29	33-1/2
3472	72	36	75	105-1/2	68	29	33-1/2
5472	72	56	85	105-1/2	68	49-1/2	43-1/2
SPLIT ROOF	72	54	85	—	68	50	44-3/8

Customized sizes are available upon request

ZYGLO® FLUORESCENT PENETRANT INSPECTION SYSTEM

DRYER STATION



All parts must be thoroughly dried during processing. If Dry Developer is used, parts are dried prior to the application of the developer. If Wet Developer is used, they are dried after the application of the developer.

MAGNAFLUX dryers provide uniform heating and air circulation throughout the drying chamber, with air intake to regulate humidity for optimum drying. Proper air circulation aids in drying and eliminates hot spots which can degrade penetrant performance.

Easy access and a large interior, along with a roller grille, accommodate high volume throughout.

An easily read and calibrated digital thermostat maintains desired temperature levels.

A dryer with solid top and balanced end doors provides virtually airtight heating. An optional dryer with a split top and flame resistant curtain doors accommodates overhead monorail conveyor systems.

FEATURES

- Structural steel framework
- Heavy gauge steel panels
- Insulated interior panels with heat reflective surfaces
- Easily removable fans and heater elements
- Adjustable, calibrated digital thermostat (N/A - on 2436)
- Air circulation fans
- Wire mesh beneath roller grille

BENEFIT

- A controlled, consistent drying cycle
- Energy efficient

MECHANICAL REQUIREMENTS

ELECTRICAL

AMPERAGE DRAW VARIES
BY MODEL AND VOLTAGE
SPECIFIED

MODEL	AMPERAGE	
	AT 230V	AT 460V
2436	32	16
4040	32	16
3448	32	16
3472	32	16
5472	48	24

Other voltages can be accommodated.
Check with your MAGNAFLUX representative.

SPECIFICATIONS

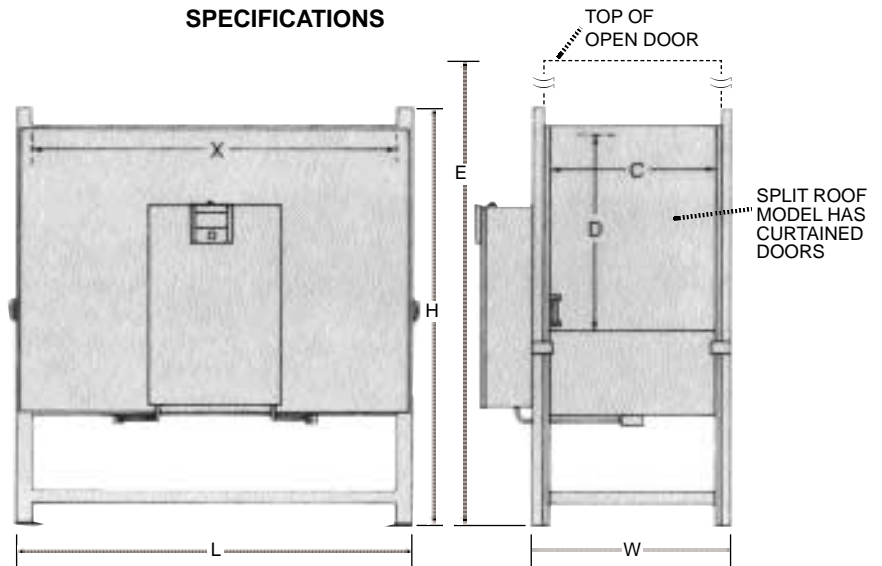

Dimensions are in inches and are nominal

STANDARD SIZE MODULAR SYSTEM	OUTSIDE DIMENSIONS				INSIDE DIMENSIONS		
	L	W	H	E	X	C	D
2436*	36	24	36	—	33	21	26
4040	40	42	82-1/2	113	36	34-1/2	33-1/2
3448	72	36	75	105-1/2	68	29	33-1/2
3472	72	36	75	105-1/2	68	29	33-1/2
5472	72	56	85	125-1/2	68	49	43-1/2
Split Roof	72	54	85	—	68	50	44-3/8

Top Loading, with corrosion resistant rack instead of rollers

Customized sizes are available upon request

INSPECTION STATION

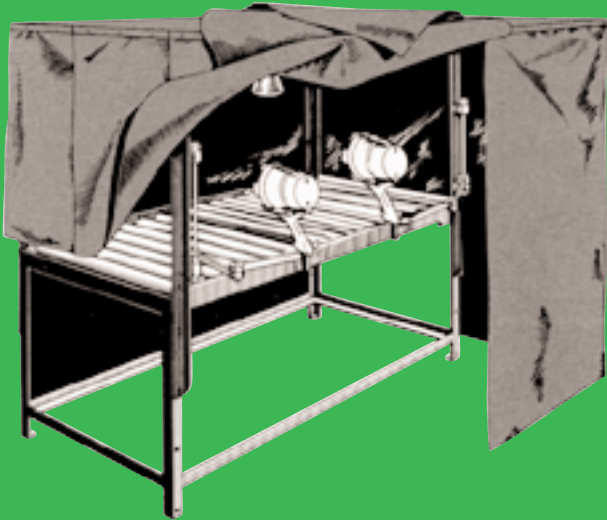

Sturdy inspection booths provide the darkened area and the black lights for thorough Fluorescent Penetrant Inspection. Ample room is provided for part handling, and roller grilles facilitate the movement of heavy or basketed parts. A solid worktop may be specified in place of the roller grille.

Flame resistant curtains extend below table height, assuring a properly darkened environment. An overhead fan provides ventilation.

A split roof model is available in the largest system to accommodate overhead monorail conveyor systems.

FEATURES

- Structural steel framework
- Roller grille (solid worktop available as option)
Note: Model 2436 available with solid worktop only
- Ventilating fan
- White light
- Black lights
- Flame resistant curtain
- Operator switch panel
- Full length curtains (4" above floor) enclose work area

BENEFITS

- Large enough to accommodate two or more inspectors
- Provides ideal environment for thorough part inspection
- Easy part entry/exit
- Comfortable work environment
- Unobstructed work area
- Meets ambient light restriction specification

ACCESSORIES

Solid worktop

MECHANICAL REQUIREMENTS

ELECTRICAL

115V, 60HZ, 1PH., 10 Amps

Other voltages can be accommodated. Check with your MAGNAFLUX representative.

SPECIFICATIONS

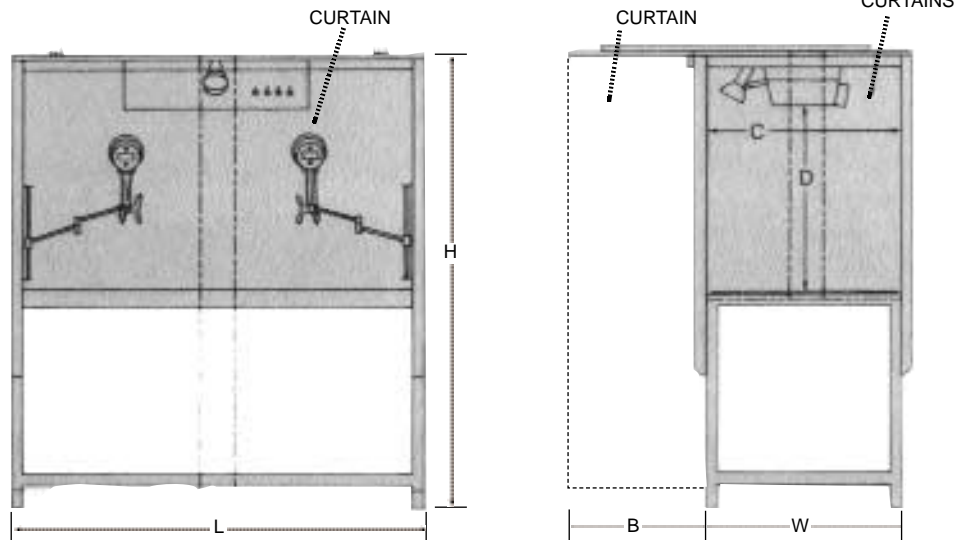

Dimensions are in inches and are nominal

STANDARD SIZE MODULAR SYSTEM	OUTSIDE DIMENSIONS				INSIDE DIMENSIONS	
	L	W	H	B	C	D
2436	36	36	83	24	36	36-3/4
4040	40	40	88-3/4	30	40	36-3/4
3448	72	34	88-3/4	30	34	31-1/4
3472	72	34	88-3/4	30	34	31-3/4
5472	72	54	88-3/4	36	54	43-1/4
SPLIT ROOF	72	54	88-3/4	36	54	43-1/4

Customized sizes are available upon request

DRY DEVELOPER STATIONS

The developer acts to pull the penetrant remaining in a cavity to the surface where it is readily visible under black light. Wet or Dry Developers may be used. Wet Developer (suspended or dissolved in water) is applied by immersion of the part. (See *Wet Developer station*)

DYNAMIC CLOUD STATION



The air in this flat bottom chamber is pre-dried and circulated at low velocity to sustain a continuous powder cloud in which the parts are placed. Powder application and evacuation cycle times are adjustable. This method involves a sealed, fully enclosed dry powder container to minimize waste due to “caking”. An optional Dust Collector is available to trap the airborne particles that are evacuated from the chamber prior to removal of parts.

FEATURES

Structural steel framework
 Roller grille
 Enclosed chamber with vertically rising doors
 Air connection with regulator and gauge
 Filtered air inlet
 Dust collection duct

BENEFITS

Even distribution of developer on parts surfaces
 Minimal developer caking
 Most efficient use of powder

ACCESSORIES

Dust collector
 Air line dryer (highly recommended)

SWIRL CLOUD STATION



The Swirl Cloud station is an air tight chamber with an air manifold and hand valve. A burst of shop air disperses Dry Developer, gently settling it onto the surface of the part. Solid end doors provide entry and exit. A Dust Collector, which requires no external ducting, is available as an option for particle evacuation.

FEATURES

Heavy Gauge stainless steel tank
 Structural steel framework
 *Roller Grille

BENEFITS

Even distribution of developer on part surfaces
 *2436 Top Loading has floor grating

ACCESSORIES

Dust collector
 Included with 2436

DEVELOPER DIP STATION



The tank for the dipping process has baffled duct work for dust collector hookup.

FEATURES

Heavy gauge stainless steel tank
 Structural steel framework
 Baffled duct work

BENEFIT

Low cost application

ACCESSORIES

Dust collector
 Half Grille

TABLE TOP DEVELOPER STATION

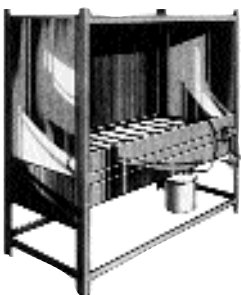

Used in place of the Developer Dip station, the Table Top Developer unit permits easy, manual application of Dry Developer.

A split roof model is available to accommodate overhead monorail conveyor systems.

FEATURES

Roller grille top
 Developer applicator hose

BENEFITS

Easy access to assure that unusually shaped parts and parts with entrapment areas are properly covered.
 Operator comfort

ACCESSORIES

Dust collector

Dry Developer may be applied by dipping (Modular Dip Developer station), by gently blowing the developer onto the part (Dynamic Cloud station) or by creating a powder "cloud" through which the parts pass (Swirl Cloud station).

NOTE: When determining floor space requirements for a Dry Developer station, allow room for a dust collector or for ducting to the plant dust collecting system.

SPECIFICATIONS

Dimensions are in inches and are nominal

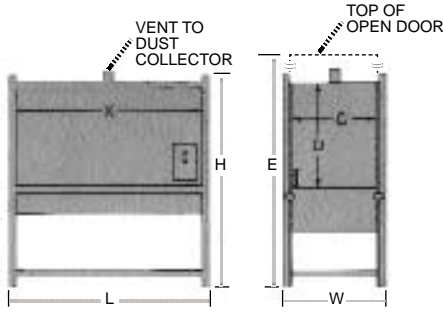

Customized sizes are available upon request

STANDARD SIZE MODULAR SYSTEM	OUTSIDE DIMENSIONS				INSIDE DIMENSIONS		
	L	W	H	E	X	C	D
2436	—	—	—	—	—	—	—
4040	40	42	85-1/4	113	36	34-1/2	33-1/2
3448	48	36	78	105-1/2	44	29	33-1/2
3472	72	36	78	105-1/2	68	29	33-1/2
5472	72	56	88	125-1/2	68	49	43-1/2

MECHANICAL REQUIREMENTS

AIR

ELECTRICAL

60 P.S.I. shop air line, 1/2" N.P.T.

115V, 60HZ, 1PH., 20 Amps

Other voltages can be accommodated. Check with your MAGNAFLUX representative.

SPECIFICATIONS

Dimensions are in inches and are nominal

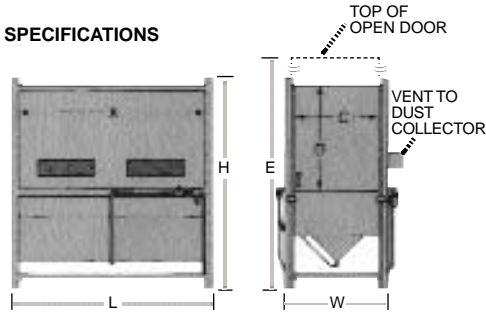

Customized sizes are available upon request

*Top Loading, not as shown

STANDARD SIZE MODULAR SYSTEM	OUTSIDE DIMENSIONS				INSIDE DIMENSIONS		
	L	W	H	E	X	C	D
2436*	36	24	36	—	33	21	26
4040	40	42	82-1/2	113	36	34-1/2	33-1/2
3448	48	36	75	105-1/2	44	29	33-1/2
3472	72	36	75	105-1/2	68	29	33-1/2
5472	72	56	85	125-1/2	68	49	43-1/2

MECHANICAL REQUIREMENT

AIR

60 P.S.I. shop air line, 1/2" N.P.T.

SPECIFICATIONS

Dimensions are in inches and are nominal

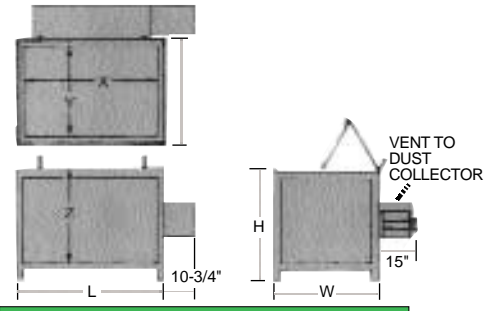

Customized sizes are available upon request

STANDARD SIZE MODULAR SYSTEM	OUTSIDE DIMENSIONS			INSIDE DIMENSIONS		
	L	W	H	X	Y	Z
2436	—	—	—	—	—	—
4040	40	42	42-1/2	36	36	36
3448	48	34	36	43-1/4	29-1/4	30-3/4
3472	72	34	36	67-1/4	29-1/4	30-3/4
5472	72	54	36	67-1/4	49-1/4	30-3/4

SPECIFICATIONS

Dimensions are in inches and are nominal

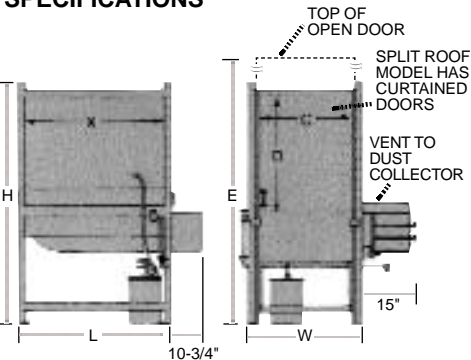

Customized sizes are available upon request

STANDARD SIZE MODULAR SYSTEM	OUTSIDE DIMENSIONS				INSIDE DIMENSIONS		
	L	W	H	E	X	C	D
2436	—	—	—	—	—	—	—
4040	<i>Available Upon Request</i>						
3448							
3472							
5472	72	56	85	125-1/2	68	49	43-1/2
SPLIT ROOF	72	54	85	—	68	50	44-1/2

MECHANICAL REQUIREMENT

AIR

60 P.S.I. shop air line

ZYGLO® FLUORESCENT PENETRANT INSPECTION SYSTEM

ACCESSORIES

POWER IMMERSION GRILLE

Air powered Immersion Grilles facilitate the lowering and raising of large parts or large baskets of parts in and out of the various processing tanks. The Immersion Grille, with its durable, corrosion resistant rollers, raises and lowers permitting rapid part drainage. Some part capacity in the tank is sacrificed.

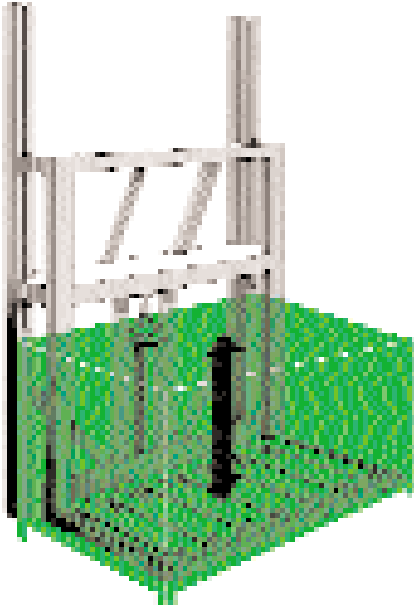

SPECIFICATIONS

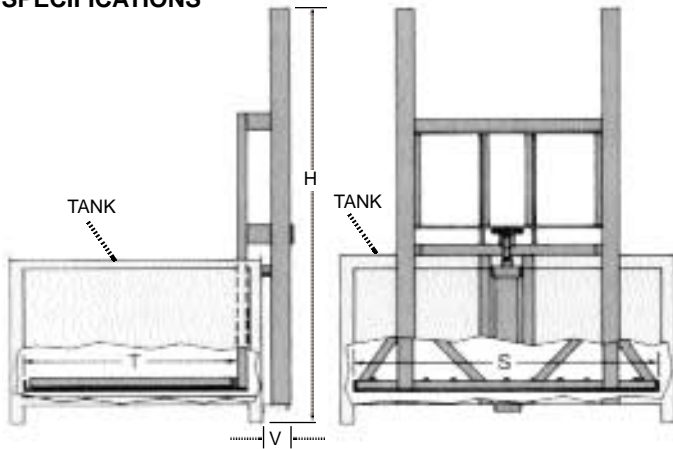

Dimensions are in inches and are nominal

STANDARD SIZE MODULAR SYSTEM	OUTSIDE DIMENSIONS		LIFT PLATFORM DIMENSIONS	
	H	V	S	T
2436	Available Upon Request			
4040	107	8	35	32
3448	96	6	41	25-1/4
3472	96	6	65	25-1/4
5472	96	6	65	45-1/4

DUST COLLECTORS

Airborne particles are evacuated from Dry Developer stations prior to the removal of parts. This steel cabinet has "positive seal" doors and requires minimal floor space.



SPECIFICATIONS

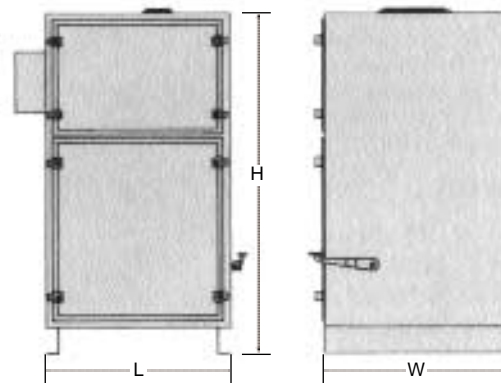

Dimensions are in inches and are nominal

Size	L	W	H	Electrical
1 HP	22-1/8	41-1/8	22-1/2	115V, 60HZ, 1PH
3 HP	28-1/8	28-1/4	52-1/8	230 or 460
10 HP	64	43-1/2	109	230 or 460

Customized sizes are available upon request

PENETRANT EQUIPMENT CHECKLIST



For assistance with quoting a Zyglo Penetrant System, please fill out the following questionnaire and fax back to Magnaflux at: 847-657-5388

Company Name: _____

Address: _____ City/State/Zip: _____

Phone Number: _____ Fax Number: _____

1. What is the part size and geometry? (Include drawing, if possible): _____

2. What is the weight of the part? _____

3. What type (level) of penetrant will be used? _____

4. Type of application? Spray Dip

5. What process for inspection is being used now, if any? _____

6. What process (water wash, lipophilic, hydrophobic) (wet/dry developer) is required? _____
 Water Wash, Lipophilic, Hydrophobic

7. What are the electrical utilities (especially electrical power) requirements and/or limitations of the facility? _____

8. What is the required processing rate or throughput? _____

9. What is the allowable floor space? (Be specific as possible. Provide expected equipment layout or footprint if possible.)

10. Does customer require: a split roof system **OR** immersion system?

11. If a conveyer system is required, are there constraints as to type? For example, overhead, roller...

12. What accessories does the customer expect to have quoted with the system?
For example, parts fixtures, baskets...

13. How is effluent being handled? Do we need a quote coalescer, nanofiltration?

14. What acceptance testing does the customer expect? At Magnaflux testing, On-site Testing, Both

15. Does the customer expect manufacturer to install the system? Yes No

16. What is the budget for the project? _____

17. What is the customer's expectation for the delivery? _____

18. When does the customer expect to make a purchasing decision? _____

MAGNAFLUX®

MAGNAFLUX
3624 West Lake Avenue
Glenview, Illinois 60025 U.S.A.
PHONE: 847-657-5300
FAX: 847-657-5388
www.magnaflux.com

UNITED KINGDOM
MAGNAFLUX, Division of ITW Limited
Faraday Road, S. Dorcan Industrial Estate
Swindon, Wiltshire, SN3 5HE, England
PHONE: 44-1793-524566
FAX: 44-1793-619498

INDIA (Licensee)
ITW SIGNODE INDIA LIMITED
5, SP Road, Begumpet
Hyderabad 500 016, India
PHONE: 91-40-814892
FAX: 91-40-849153

Authorized MAGNAFLUX representative



MAGNAFLUX®

A Division of Illinois Tool Works Inc.